

NR	TEILE NR. PART NO.	BENENNUNG	DESCRIPTION	NR	TEILE NR. PART NO.	BENENNUNG	DESCRIPTION
1	482.816.0	Ventileinheit DRV kpl.	VALVE UNIT DRV COMPL.	16	387.836.8	ET-Spreizerspitze SP60	JAW SP60
2	483.713.9	Schraube MA=40+10Nm	SCREW MA=40+10Nm		387.837.6	ET-Spreizerspitze SP80	JAW SP80
3	482.749.0	Stützring	BACK UP RING	17	810.609.6	Druckstück	SETScrew
4	080.373.1	O-Ring	O-RING	18	181.205.0	Spreizarm SP60	SPREADER ARM SP60
5	052.383.6	Druckfeder	PRESSURE SPRING		181.407.9	Spreizarm SP80	SPREADER ARM SP80
6	482.625.6	Ventilstift	VALVE PIN	19	283.619.0	Schutzblech	GUARD PLATE
7	080.097.0	Kugel	BALL	20	811.986.4	Linseflanschschraube	LENS FLANGE SCREW
8	482.714.7	Buchse	BUSHING	21	484.528.5	Bügel	FASTENING
9	482.715.5	Ventilsitz	VALVE SET	22	181.199.1	Zylinder	CYLINDER
10	482.717.1	Druckfeder	PRESSURE SPRING	23	082.219.1	Sicherungsring	LOCKING RING
11	482.716.3	Steuerschieber	SPOOL VALVE	24	484.490.4	Bolzen	PIVOT PIN
12	080.834.2	Gleitring mit O-Ring	SEAL RING INCL. O-RING	25	485.279.6	Schutzblech	GUARD PLATE
13	484.162.0	Schraube MA=40+10Nm	SCREW MA=40+10Nm	27	387.882.1	Gelenkstück	TOGGLE JOINT
14				28	386.562.2	Schwenkauge	BOLT HOLE MOUNTING
15	485.097.1	Bolzen SP60 + O-Ring	PIVOT PIN SP60 + O-RING			MA=350Nm	MA=350Nm
	485.127.7	Bolzen SP80 + R-Ring	PIVOT PIN SP80 + O-RING	29	A B 484.479.3	Stützring	BACK UP RING
				30	A B 081.520.9	O-Ring	O-RING
				31	085.242.2	Schraube MA=20+2Nm	SREW MA=20+2Nm
				32	387.013.8	Haltegriff	HANDLE
				33	A B 082.817.3	Abstreifer	OIL WIPER RING
				34	A B 811.844.2	Stangendichtung	ROAD SEALING

**C** GEFÜGT MIT LOCTITE 245  
JOINT WITH LOCTITE 245

**D** GEFÜGT MIT LOCTITE 480  
JOINT WITH LOCTITE 480

**E** GEFÜGT MIT LOCTITE 638  
JOINT WITH LOCTITE 638

NR	TEILE NR. PART NO.	BENENNUNG	DESCRIPTION
35	386.564.9	Führungsstück	GUIDE PART
36	A B 484.667.2	Stützring	BACK UP RING
37	A B 081.215.3	O-Ring	O-RING
38	386.563.0	Kolbenstange	PISTON
39	A B 811.850.7	Gyltring	GLYD-RING
40	A B 084.561.2	Führungsring	WEAR RING
41	A B 406.976.5	Stützring	BACK UP RING
42	A B 812.070.6	Stangendichtung	ROAD SEALING
43	406.974.9	Buchse	SLEEVE
44	407.480.7	Sicherungsring	LOCKING RING

NR	TEILE NR. PART NO.	BENENNUNG	DESCRIPTION
45	E 386.568.1	Rohr MA=10+5Nm	TUBE MA=10+5Nm
46	A B 081.499.7	O-Ring	O-RING
47	812.489.2	Scheibe	WASHER
48	484.820.9	Buchse	SLEEVE
49	C 801.240.7	Senkkopfschraube	COUNTERSUNK SCREW
50	387.016.2	Haltegriff	HANDLE
51	811.346.7	Zylinderschraube	SOCKET HEAD SCREW
52	A B 080.956.0	Dichtring	SEALING RING
53	484.429.7	Ventileinheit DBV kpl.	VALVE UNIT DBV COMPL.
54	A B 810.577.4	Dichtring	SEALING RING
55	084.739.9	Gewindestift	SETSCREW
56	080.720.6	Kugel	BALL
57	484.588.9	Druckknopf konvex	KNOB CONVEX
58	055.179.1	Steuergriff kpl.	CONTROL HANDLE COMPL.
59	051.627.9	Filter	FILTER
60	066.095.7	Blende	FLOW RESTRICTOR
61	402.434.6	Buchse	SLEEVE
62	386.416.2	Hülse	TUBE
63	A B 080.748.6	Dichtring	SEALING RING
64	038.158.6	Schlauch 0,5m gelb	HOSE 0,5m; YELLOW
65	312.695.1	Schutzkappe	PROTECTIVE CAP
66	060.835.1	Kupplungsstecker	COUPLING PLUG
67	312.694.3	Schutzstopfen	PROTECTIVE STOPPER
68	387.587.3	Kupplungsmuffe	COUPLING MALE
69	089.842.2	Zylinderschraube	SOCKET HEAD SCREW
70	484.158.1	Buchse	SLEEVE
71	386.423.5	Schutzbügel	FASTENING
72	801.402.7	Scheibe	WASHER
73	484.587.0	Druckknopf konkav	KNOB CONCAVE
74	A B 800.293.2	O-Ring	O-RING
75	484.555.2	Typenschild SP60	TYPE PLATE SP60
	484.985.0	Typenschild SP80	TYPE PLATE SP80
76	409.429.8	Schild	PLATE
77	084.738.0	Kabelrappband	HOSE CLIPE
78	810.504.9	Schild	PLATE
79	C 812.225.3	Senkkopfschraube	COUNTERSUNK SCREW
80	080.155.0	Scheibe	WASHER

**A** Dichtsatz kpl. Teile Nr. 811.947.3  
SEALING SET COMPL. PART NO.: 811.947.3

**B** Diese Positionen sind nicht als Einzelteile lieferbar  
THESE POSITIONS ARE NOT DELIVERABLE

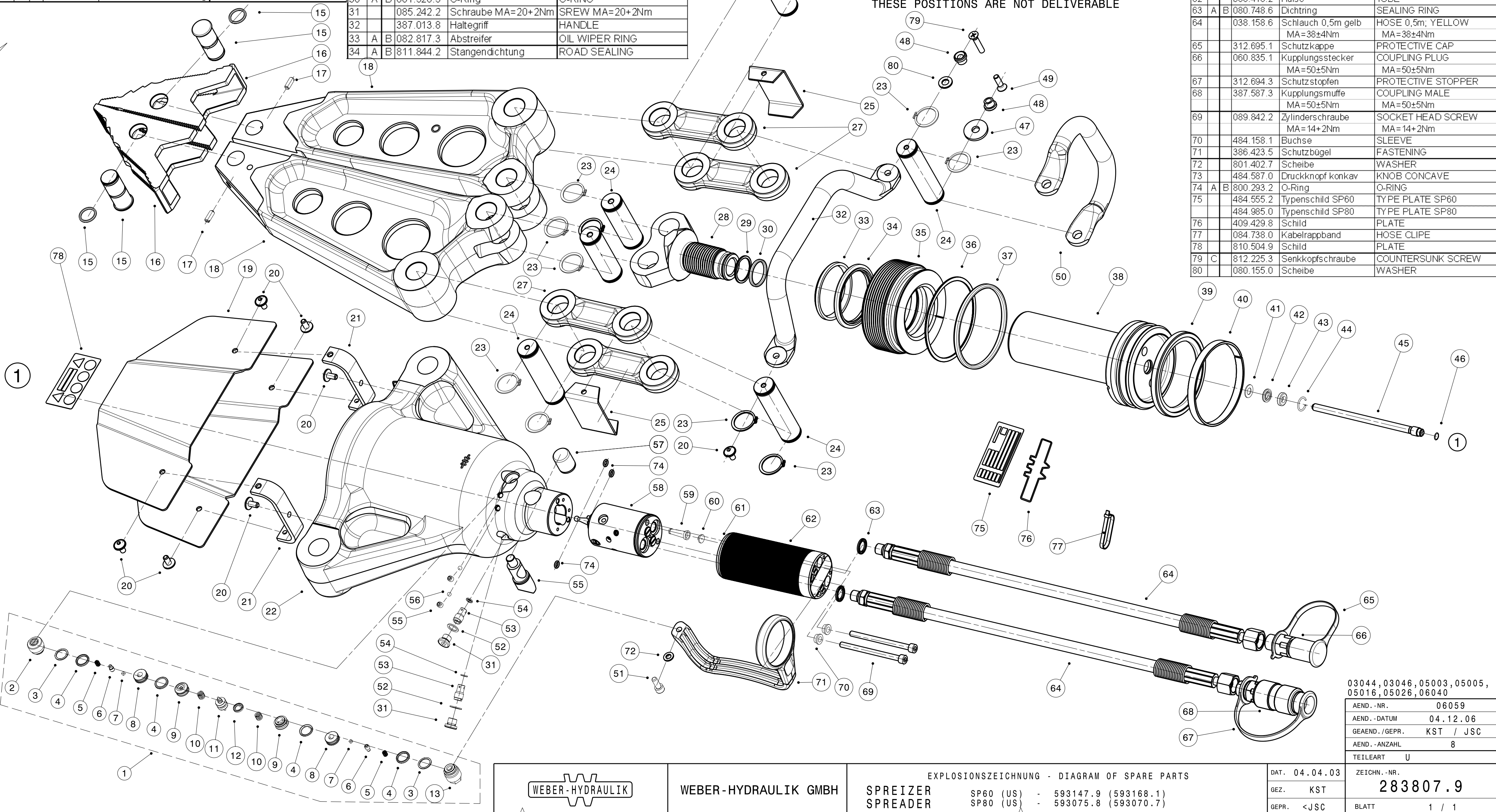

WEBER-HYDRAULIK GMBH

SPREIZER  
SPREADER

EXPLOSIONSZEICHNUNG - DIAGRAM OF SPARE PARTS

SP60 (US) - 593147.9 (593168.1)  
SP80 (US) - 593075.8 (593070.7)

DAT. 04.04.03

GEZ. KST  
GEPR. <JSC

03044, 03046, 05003, 05005,  
05016, 05026, 06040

AEND.-NR.	06059
AEND.-DATUM	04.12.06
GEAEND./GEPR.	KST / JSC
AEND.-ANZAHL	8
TEILEART	U

ZEICHN.-NR.

283807.9

BLATT 1 / 1